



新品
NEW



铜泵头
BRASS HEAD



铝合金连杆
CONNECTING-RODS
IN ALUMINIUM

JR / JR-M



414 Series

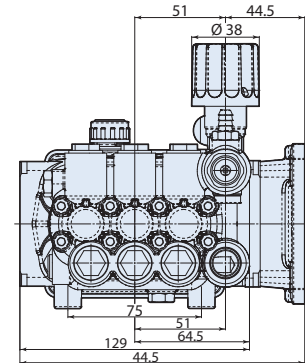
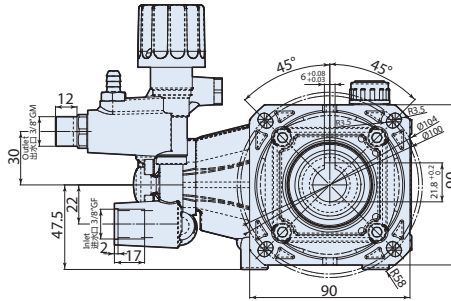

型号	流量 l/min gpm	压力 bar psi	电机功率 hp kw	重量 kg	转速 rpm	温控阀 TRV	进水口	出水口	易启动	皂液嘴	TSS	编号
JR-M 1450 转 C 轴 19mm 空心轴 + F48 法兰 - 适用于电机 MEC 80												
JR-M 01.10 C DX + F48	1 0.3	100 1450	0.3 0.2	4	1450	无	3/8"GF	3/8"GM	无	无	无	26315
JR-M 02.10 C DX + F48	2 0.5	100 1450	0.5 0.4	4	1450	无	3/8"GF	3/8"GM	无	无	无	26314
JR-M 04.10 C DX + F48	4 1.1	100 1450	1.1 0.8	4	1450	无	3/8"GF	3/8"GM	无	无	无	26313
JR-M 05.10 C DX + F48	5 1.3	100 1450	1.3 1.0	4	1450	无	3/8"GF	3/8"GM	无	无	无	26312
JR 1450 转 C 轴 19mm 空心轴 + F48 法兰 - 适用于电机 MEC 80												
JR 05.15 C DX + F48	5 1.3	150 2175	2 1.5	4	1450	无	3/8"GF	3/8"GM	无	有	无	25662

Model	流量 l/min gpm	压力 bar psi	Power hp kw	重量 kg	转速 RPM	TRV	Inlet	Outlet	EZ Start	Injection	TSS	Code
JR-M 1450 RPM C version 19mm with flange F48 for el. motor MEC 80												
JR-M 01.10 C DX + F48	1 0.3	100 1450	0.3 0.2	4	1450	No	3/8"GF	3/8"GM	No	No	No	26315
JR-M 02.10 C DX + F48	2 0.5	100 1450	0.5 0.4	4	1450	No	3/8"GF	3/8"GM	No	No	No	26314
JR-M 04.10 C DX + F48	4 1.1	100 1450	1.1 0.8	4	1450	No	3/8"GF	3/8"GM	No	No	No	26313
JR-M 05.10 C DX + F48	5 1.3	100 1450	1.3 1.0	4	1450	No	3/8"GF	3/8"GM	No	No	No	26312
JR 1450 RPM C version 19mm with flange F48 for el. motor MEC 80												
JR 05.15 C DX + F48	5 1.3	150 2175	2 1.5	4	1450	No	3/8"GF	3/8"GM	No	Yes	No	25662